



**Asia-Pacific
Economic Cooperation**

Advancing
Free Trade for Asia-Pacific
Prosperity

The Current Status and Future Prospects of ITS in China

23 April 2018

FANSHENG XING, Department of Science & Technology
Ministry of Transport, P.R.CHINA

Primary Content



Asia-Pacific
Economic Cooperation

- **Development Path**
- **The Main Features of Current ITS**
- **Typical Application**
- **Future Prospects**

Part 1



Asia-Pacific
Economic Cooperation

➤ Development Path

➤ The main results

➤ Typical APEC

➤ The future

1. Development Path (1/5)



Asia-Pacific
Economic Cooperation

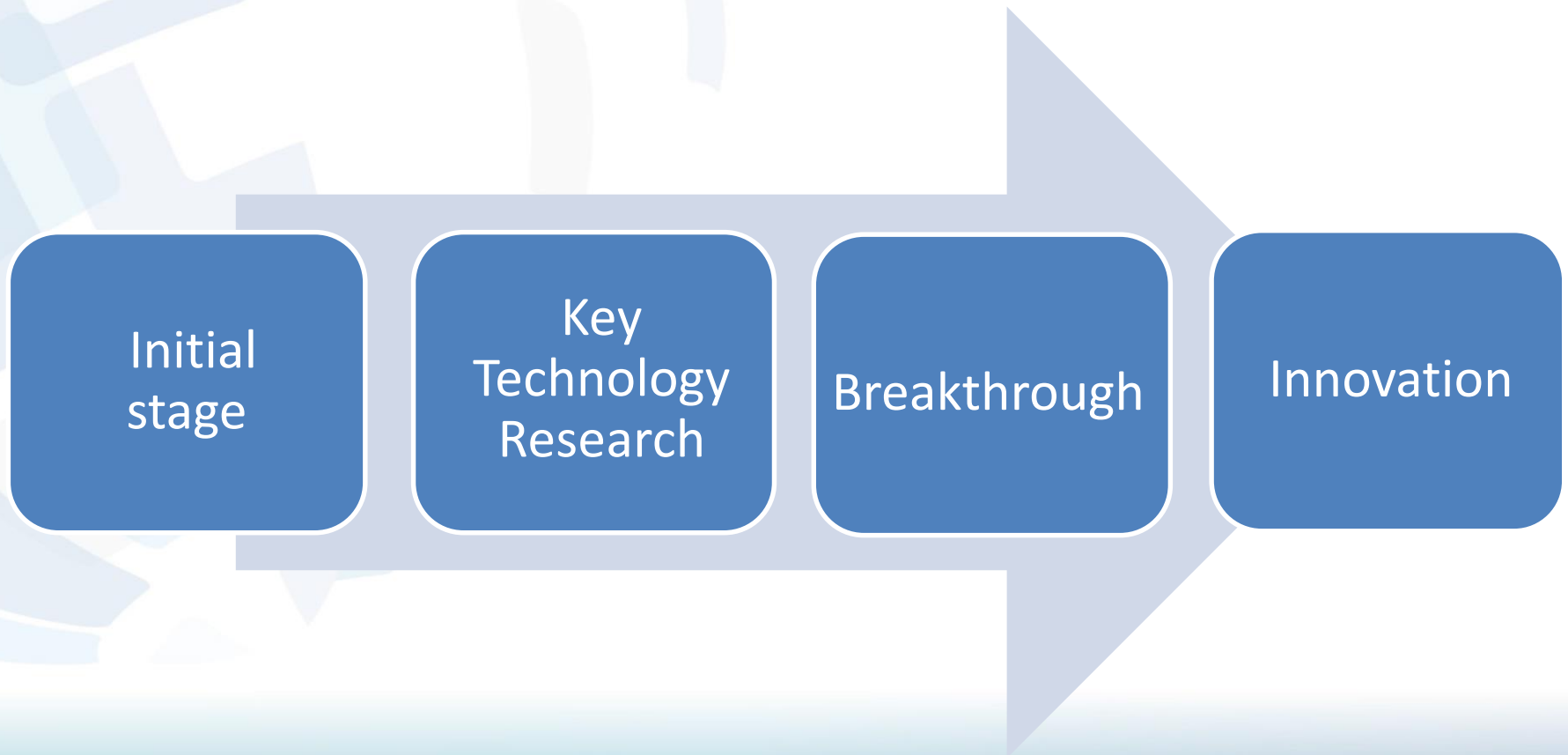

Initial
stage

Key
Technology
Research

Breakthrough

Innovation

1. Development Path (2/5)



Asia-Pacific
Economic Cooperation

1.1 Initial stage : 1970–2000

- During the late 1970s, China Started ITS research
- In the mid-1990s, the "Intelligent Transportation Development Strategy" was researched and the system framework of China's intelligent transport system (first edition) was compiled.
- In 2000, the Domestic Intelligent Transportation System (ITS) Coordination Steering Group and Office were established.

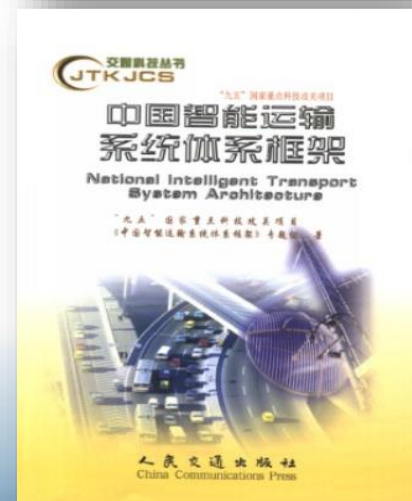
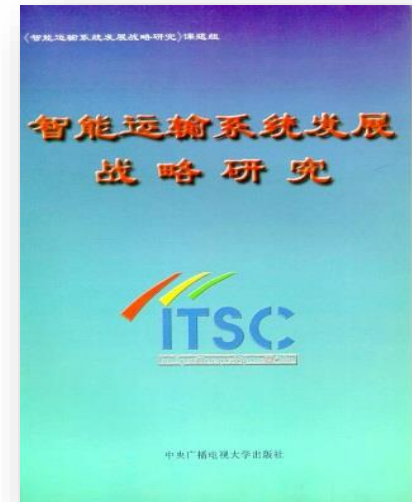

1. Development path (3/5)



1.2 Key Technology Research : 2001-2010

- 2001, Launched a Major Project on the Development and Demonstration of Key Technologies for Intelligent Transportation Systems.
- 2003, Established “Domestic Standardization Technical Committee for Intelligent Transport Systems” (corresponding to ISO/TC204).
- Demonstration construction: 13 cities such as Beijing, Shanghai, Tianjin, Chongqing, Guangzhou and Shenzhen.
- R&D: A batch of key technologies, special equipment and application systems.

1. Development path (4/5)

1.3 Breakthrough : 2011–2015

- Carry out the “Domestic Intelligent Transportation Integrated Technology Integration and Application Demonstration” and “Integrated Technology Development and Demonstration Application of Comprehensive Prevention and Disposal of Serious Traffic Accidents”;
- Two-piece modular electronic ETC rapid development;
- Standard system and DSRC-ETC application detection system continue to improve;
- Establishing a Domestic Transportation Logistics Public Information Platform



1. Development path (5/5)



1.4 Innovation : 2016–

- Planning: “Implementation plans of promoting ‘Internet + convenient transportation’ and intelligent transport development ”
“Action plan of promoting the development of smart transport (2017-2020)”
- Standards: Communication application technology, Cooperation ITS technology, Mobile Internet technology for transportation, Security’s management of traffic information, etc. are included in the domestic standard system.
- Application: A New Generation of Domestic Traffic Control Networks and Intelligent Roads, Demonstration Project of Comprehensive Transportation Information Service Based on Government-enterprise Cooperation.

Part 2



Asia-Pacific
Economic Cooperation

➤ **The Main Features of Current ITS**

➤ Typical A...

ur...

2. The main features of Current ITS (1/1)



The main features of Current ITS are shown in five aspects:

- ① Promoter: Internet Technology Background Company + Capital.
- ② Focus: Automated driving, travel and service, and smart logistics.
- ③ Development model: socialization of products and services, social applications, Rapid iterative research and development to industry monopoly.
- ④ Development trends: the trend of Intelligentization, Electricization, and Networking are increasingly obvious.
- ⑤ Application object: urban tourism and logistics.

Part 3



Asia-Pacific
Economic Cooperation

➤ Typical Application

3. Typical Application (1/7)

3.1 ETC(Electronic Toll Collection)

- By the end of February 2018, the number of ETC users has exceeded 62.9078 million, 17,644 ETC lanes. Mainline-Tolls-Station' ETC lane coverage is about 99% , Ramp-Tolls-Station's ETC lane coverage is about 90.5%, the Service network has covered all county (district) level areas.

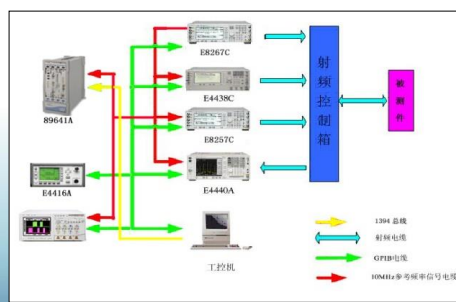
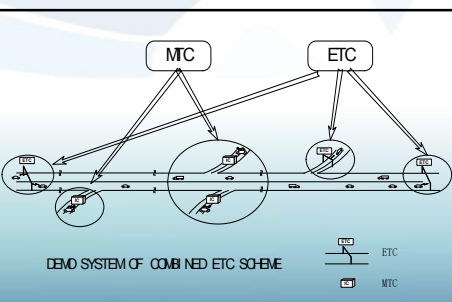

3. Typical Application (2/7)



3.2 Road Network Operation Monitoring System

- The total number of expressway traffic parameter monitoring facilities in China amounts to 20,000 sets, with an average deployment density of 10-15 km/set. The total number of video surveillance facilities along the road line amounts to 48,000 sets with an average deployment density of 5 km/set. More than 40% of the key road sections of the highway network, as well as super-large bridges and special long tunnels, have dynamically monitored the operating conditions.

3. Typical Application (3/7)



Asia-Pacific
Economic Cooperation

3.3 Integration of Transportation Card

- The “Integration of transportation card” has achieved interoperability in 190 cities, and its sales volume was 430 million, 38.02 billion passengers using. Transit Metropolis was built in 37 cities, 26 of which carried intelligence public transportation application demonstration project.



3. Typical Application (4/7)



3.4 Intelligent Roads

- The General Office of the Ministry of Transport of China has given out a notice about the decision of accelerating pilots of a new generation of Domestic traffic control networks and intelligent roads in Beijing, Hebei, Jilin, Jiangsu, Zhejiang, Fujian, Jiangxi, Henan and Guangdong .
- It will focus on 6 aspects, such as Digital infrastructure. The intelligent upgrade of highway system (roadside) and integration and coordination of operation of the vehicle road transport. BDS high precision positioning application. Road Network Comprehensive Management Based on Big Data. "Internet +" road network services. A new generation of national traffic control networks.

3. Typical Application (5/7)



3.5 Automated Driving

- The Chinese government has successively put forward strategies such as “Made in China 2025” and “Internet +” development, expounding the innovation trend and promotion path of automated driving technological and Intelligent connected vehicle, clarifying the corresponding guiding policies and demonstration projects. Proposed guidance policies and demonstration projects.

3. Typical Application (6/7)



3.5 Automated Driving

- MOT attaches great importance to research on autonomous driving technology, and focused on the following work:
 - a) Establish working mechanism.
 - b) Study and formulate standard policies.
 - c) Actively promote technology R&D.
 - d) Deploy and build test bases.

3. Typical Application (7/7)



3.5 Automated Driving

- At present, Beijing, Shanghai, Chongqing have issued the road-test regulations of automated driving, allowing and standardizing the automatic driving test. Shanghai and Beijing have issued the test license plate on the road.

Part 4



Asia-Pacific
Economic Cooperation

- ▶ The main results
- ▶ Typical APEC
- ▶ **Future Prospects**

4.Future Prospects (1/1)



Asia-Pacific
Economic Cooperation

(1) Transportation Infrastructure
Energy Supply.



(2) Open, shared and coordinated
road transport service system.



(3) Next generation of Carrier
Tools and Transportation Systems.





Asia-Pacific
Economic Cooperation

Thanks!

Follow us on social media



www.apec.org



www.facebook.com/APECnews



@APEC and @Bollard_APEC



www.linkedin.com/company/asia-pacific-economic-cooperation-apec-secretariat